



Please read and save these instructions. Read carefully before attempting to assemble, install, operate or maintain the product described. Protect yourself and others by observing all safety information. Failure to comply with instructions could result in personal injury and/or property damage! Retain instructions for future reference.

PENN BARRY™

# Fumex (Standard, Heat & Smoke & Restaurant Exhaust) Centrifugal Roof & Wall: Direct & Belt Drive Exhausters



## Receiving and Handling

PennBarry fans are carefully inspected before leaving the factory. When the unit is received, inspect the carton for any signs of tampering. Inspect the unit for any damage that may have occurred during transit and check for loose, missing or damaged parts. Mishandled units can void the warranty provisions. If units are damaged in transit, it is the responsibility of the receiver to make all claims against the carrier. PennBarry is not responsible for damages incurred during shipment.

Avoid severe jarring and/or dropping. Handle units with care to prevent damage to components or finishes. If the unit is scratched due to mishandling, the protective coating may be damaged. Incorrect lifting may damage the fan and void the warranty.

## Storage

Long-term storage requires special attention. Store units on a level, solid surface, preferably indoors. If outside storage is necessary, protect the units against moisture and dirt by encasing the cartons in plastic or in some similar weatherproof material. Periodically inspect units and rotate wheels to spread bearing lubricant. Failure to rotate wheels results in reduced bearing life and may void the manufacturer's warranty. If the unit will be stored for an extended time, remove belts. Belts which remain under tension in a stationary position for extended periods are likely to have a reduced operating life.

## Description

Designed for severe service removing foul air from industrial and commercial buildings, laboratory fume hoods. Housing and wheel constructed of aluminum; heat and smoke removal utilizes a steel wheel. Motor compartment externally cooled and located out of the discharge airstream. Power ventilators suitable for Restaurant Exhaust Appliances (YZHW) are accordingly labeled. Power ventilators suitable for smoke removal are accordingly labeled. These units require installation according to NFPA-96 standards, local codes and general practices. Up to Model 24B are available wall mounted (WFX).

## Unpacking

Place the carton in an upright position and remove the staples or use a sharp (knife edge) tool to carefully cut or scribe the sealing tape on both sides at the top of the carton. Open carton flaps. Remove any cardboard and wooden filler pieces, as well as loose components or accessories shipped with the unit.

Carefully remove the unit from the carton. Inspect the unit for any damage that may have occurred during transit and check for loose, missing or damaged parts.

## Installation

### ⚠ CAUTION

*When the unit is installed on a sloped roof, suitable footing and/or other safety devices must be provided around the ventilator for normal maintenance. Depending upon the site conditions, the hinging of the ventilator off the curb during maintenance should be either parallel to the roof ridge or toward the roof ridge, but NOT away from the ridge.*

### ⚠ CAUTION

*NFPA-96 recommends that dampers should not be installed when exhauster is used for the removal of smoke and grease laden vapors from commercial cooking equipment. Consult state and local codes for detailed requirements.*

### ⚠ NOTE

*For installation in high velocity hurricane zones, Unit must be installed per instructions on page 5.*

Figure 1: Roof Curb Installation

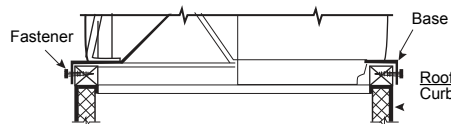

## DAMPERS: ROOF MOUNTING

When required, install dampers prior to mounting the unit on the curb or frame. Dampers are sized to fit within the roof opening. Secure using standard hardware. If the damper is installed on the inside of the curb, a piece of wood may be required as a "spacer". Do not twist or distort the damper frame. Damper frame must be reasonably level on all sides. Check for free operation. If dampers are motor operated type, ascertain that proper voltage is applied on motor terminals.

## ANCHORING AND INSTALLING THE VENTILATOR

Roof mounting may be in accordance with the latest edition of NFPA-96 and local codes. If not specified by codes), secure unit to curb through pre-punched holes in the ventilator base vertical flange (see Figure 1 below).

In order to complete some installations, specifically kitchen exhaust, you will require an 18" high curb as well as a weather resistant junction box and hinge assembly.

Guy down large units installed in areas subject to high winds or unusual field conditions. If the installer removes any ventilator parts to facilitate installation or electrical connection, reassemble all parts by replacing all spacers, washers, nuts, bolts, fasteners and components exactly as they were found prior to removal. Draw all fasteners tight and secure.

FLOATING HINGE INSTRUCTIONS

1. If any gasket is to be field installed, this should be completed before installing the floating hinge. If a grease collection box will be installed, it should be installed after installing the floating hinge, and not on either the hinge or handle sides of the unit.
2. If this item is provided, hardware is included. Review figure 2 for illustrations regarding this installation. Detailed instructions should be provided with the hinge kit, which are summarized below. The hinge kit instructions take precedence over these instructions.
3. Take back plate and position inside the pedestal to allow for the pedestal metal thickness, flush with both the top and rear vertical surfaces. Use this plate as a template to mark the hole locations. Drill two clearance holes. Do this for both sides of the pedestal.
4. Bolt both back plates in place INSIDE the pedestal. Slide bushing over the rear most back plate bolt.

Figure 3: Wall Mount Installation

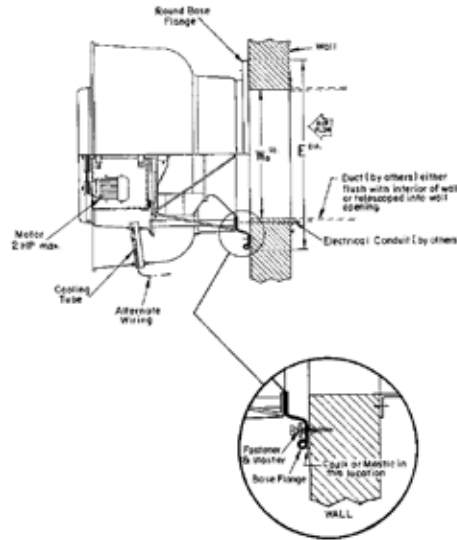

5. Insert 2 bolts through pre-punched holes on each side of the ventilator base.
6. Position the ventilator on top of the pedestal. Install the floating hinge by aligning the slotted hole over the bushing (on rear most bolt) and onto the two bolts on the ventilator base. Fasten with nuts and tighten. Install nut over bushing. The forward back plate bolt functions as a stop; nothing is attached to it.
7. Install the lift handle and hold down lugs to ventilator base through the pre-punched holes.
8. Using the hold down lug as a template, drill on both sides of the pedestal to install wing nut hardware. When installed, tighten firmly.

Table 1: Wall Mount Dimensions

Model	E DIA	Wo <sup>sq</sup>
WFX08	24	9
WFX10-WFX13	11 & 24	11 1/2
WFX8B-WFX14B	27 1/4	16 1/4
WFX16	24	40 1/4
WFX16B-WFX18B	29 1/2	20
WFX24B	35 7/8	25

Figure 2: Floating Hinge Installation

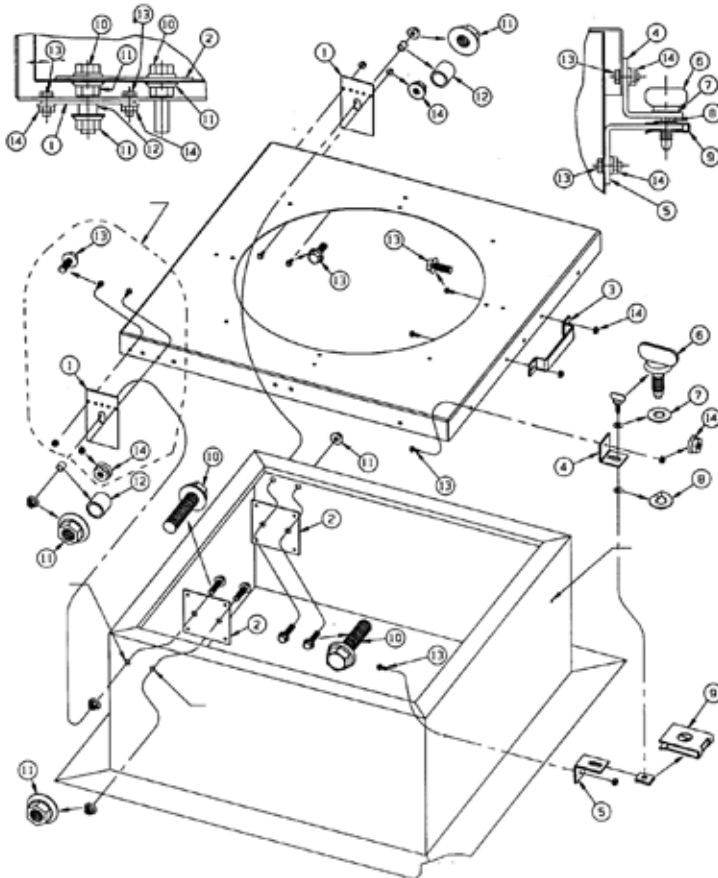

WALL MOUNTING

Fumex fans are available with round bases to facilitate wall mounting through size 24B (WFX). If installing these units, ensure the wall mounting surface is leak-free. To assure weather-tightness, coat the entire rear side (that portion which mates with the wall) of the mounting flange with a suitable caulking compound or an approved waterproof mastic sealer.

On masonry walls, attach the base flange with lead cinch type anchors and a non-ferrous bolt. On sidings, use nonferrous lag bolts. Washers are recommended to be used under the bolt heads.

Table 2: Floating Hinge Parts List

Ref. #	Description
1	Floating Hinge
2	Back Plate
3	Lifting Angle
4	Hold Down Lug (short)
5	Bottom Lug (long)
6	Thumb Screen
7	Plastic Washer for Screw
8	Metal Hold Washer for Screw
9	Retaining Clip
10	3/8"-16 X 1 1/2 Whiz Bolt
11	3/8"-16 Whiz Nut
12	1/2-3/8 X 3/8 Lg. Bushing
13	10-32 X 1/2 Whiz Bolt
14	10-32 Whiz Nut

**Positioning and Running Power Lines**

**ROOF MOUNTING**

Power is normally brought from within the building through proper conduit lines and placed inside the curb. Feed power through the ventilator to the (Disconnect Switch or Junction Box) motor. Wiring can be brought through the cooling tube from the outside; this is the method to be used for NFPA96, as well as smoke controll systems installations if an external disconnect junction box is not already provided.

**WALL MOUNTING**

Power is normally brought up from within the building through proper conduit lines to the wall opening, then fed to the (Disconnect Switch or Junction Box) motor. Wiring can be brought through the cooling tube from the outside; this is the method to be used for NFPA96 installations if an external disconnect junction box is not already provided.

**Start-Up and Operation**

Carefully inspect the unit before startup. All motor bearings should be properly lubricated and all fasteners should be securely tightened. Rotate centrifugal wheel by hand to insure free movement. Before placing hand on centrifugal wheel or belts, lock out the power source. Check all set-screws and keys. Tighten when necessary. Check the condition of belts and the amount of tension prior to start-up. DO NOT overtighten, as bearing damage will occur.

Recommended belt tension should permit deflection of 1/64" per inch of span. Exercise extreme care when adjusting belts as not to mis-align pulleys. Any misalignment will cause a sharp reduction in belt life and can produce excess belt noise. (see Figure 4). On units equipped with two groove pulleys, adjust all belts with equal tension.

**Figure 4: Pulley Alignment & Tension**

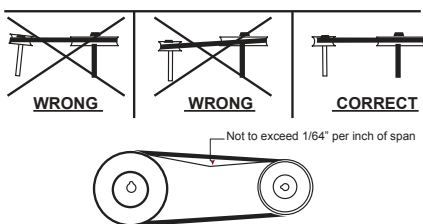

Belts must be adjusted after approx. 40 hours of operation.

**CAUTION** *Whenever belts are removed or installed, never force belts over pulleys without loosening motor first to relieve belt tension.*

Make sure inlets and approaches to the unit are free from obstruction. To assure maximum air movement, make sure adequate supply air is available to ventilated space.

When power lines are brought up to the unit, provide a generous amount of slack to allow for motor adjustments and to permit movement of motor for belt tension adjustments. Ground motor adequately and securely. Protect power lines from sharp objects. Do not kink power line or permit it to contact hot surfaces, chemicals, grease or oil. Use only UL recognized electrical parts, rated for proper voltage, load and environment.

Before putting fan into operation, complete the following check list:

- a. Turn off and LOCK OUT the power source.
- b. Make sure installation is in accordance with manufacturer's instructions.
- c. Check and tighten all fasteners.
- d. Spin centrifugal wheel to see if rotation is free.
- e. Check all set-screws and keys: tighten if necessary.
- f. Torqued set screws have a colored Torque Seal mark indicating the correct torque has been applied.
- g. Check belt or direct drive coupling for alignment
- h. Check belt for proper belt tension

- i. Make sure there is no foreign or loose material in ductwork leading to and from fan or in the fan itself.
- j. Properly secure all safety guards.
- k. Secure all access doors to fan and ductwork.
- l. Check line voltage with motor nameplate.
- m. Check wiring.

**CAUTION** *On single phase motors, the terminal block must be set up in accordance with the nameplate instructions and/or wiring diagram. This set up must match the line voltage. If the motor is multi-speed or multi-voltage, the winding leads must be grouped and connected as shown on the motor wiring diagram. The line voltage must correspond with proper grouping of motor leads. The wiring diagram must be followed explicitly or serious motor or starter damage will occur.*

Do not operate models from line frequencies higher than 60Hz + or -5% with standard motors.

The ventilator has been checked at the factory prior to shipment for mechanical noises. If mechanical noises should develop:

- a. Check rotating component for adequate clearance and direction of rotation. See page 6 for the wheel alignment procedure. See top of plate for wheel direction.
- b. Check proper belt tension and pulley alignment.
- c. Check installation and anchoring.
- d. Check fan bearings.
- e. Check that cooling tube is in place and well sealed.

**CAUTION** *Incorrect rotation overloads motor severely and results in serious motor damage. To change rotation of three phase units, interchange any 2 of the 3 line leads. On single phase units, change the terminal block set-up following the wiring diagram on the motor.*

f. Check motor and bearing temperature for excessive heat.

**CAUTION** Use care when touching the exterior of an operating motor. Modern motors normally run hot. They are designed to operate at higher temperatures. This is a normal condition but they may be hot enough to be painful or injurious to the touch.

If any problem is indicated, TURN OFF POWER TO UNIT IMMEDIATELY. Lock out the electrical supply, check carefully for the cause of the trouble and correct as needed. Even if the fan appears to be operating satisfactorily, shut down after a brief period and check all fasteners, set-screws and keys for tightness.

During the first eight (8) hours of operation, check the fan periodically for excessive vibration or noise. At this time, also check motor input current and motor bearing temperatures to insure that they do not exceed manufacturer's recommendations. After eight hours of satisfactory operation, shut down the fan and lock out the electrical power to check the following items and adjust if necessary:

- a. All set-screws, keys and fasteners.
- b. Belt alignment.
- c. Belt tension.

**Maintenance**

Do not attempt maintenance on the fan until the electrical supply has been completely disconnected. If a disconnect switch has not been provided, remove all fuses from the circuit and lock the fuse panel so they cannot be accidentally replaced.

Lubrication is a primary maintenance responsibility. Check all bearings periodically. Inspect belts for tightness. If the fan is installed in a corrosive or dirty atmosphere, periodically clean the centrifugal wheel, inlet, motor housing and other moving parts.

**FAN SHAFT LUBRICATION**

Fan shaft bearing pillow blocks are furnished in either the pre lubricated sealed-for-life type or the greasable type. The prefabricated type requires no servicing for 7 to 10 years of normal use. Follow the lubricating schedule recommended by the factory. This practice should not supersede any safety considerations.

**CAUTION** Use low pressure grease guns only. High pressure guns tend to blow out or unseat bearing seals, leaving the bearing open to collect grime, dust and foreign particles.

**LUBRICATION SCHEDULE**

Always follow the bearing manufacturer's recommended lubrication schedule. If none is available use the following general schedule.

- a. Under average conditions where ambient temperatures do not exceed 120°F, lubrication is required 1 to 2 times a year.
- b. Under dirt laden atmosphere where there is a temperature range of 120°F to 150°F, lubrication is required from 3 to 6 times a year.
- c. Under extreme temperature conditions and extremely dirty atmospheres, lubrication should be scheduled at least once or twice a month.
- d. Belt drive units maximum temperature should not exceed 160°F. Direct driven models have temperature range stamped on motor.

**MOTOR LUBRICATION**

In general, standard motors are furnished with prelubricated, sealed-for-life ball bearings which require no lubrication for 7 to 10 years of normal service. Where motors have been ordered with greasable bearings, these bearings are factory lubricated and require no attention for one year under normal conditions. If grease relief fittings are provided, remove them when performing maintenance to allow grease to flow out. Whenever possible, apply grease while the motor is running. This practice should not supersede any safety considerations. DO NOT OVER-GREASE, as most lubricants deteriorate motor windings, thereby reducing motor life.

**Table 3: Recommended Lubricants**

Manufacturer	Product	Temp. Range
BP	LG-#P-1	Below 32°F (0°C)
Gulf	Gulfcrown EP-1	
Imperial Oil	Unirex EP-1	
Shell	Alvania R-1	32°F to 150°F (0°C to 66°C)
BP	Energrease, MPMK11	
Gulf	Gulfcrown EP-2	
Imperial Oil	Unirex EP-2	
Shell	Alvania R-3	
Sun Oil	Sun Prestige 42	
Texaco	Regal AFB2	

**Guards**

All fans have moving parts which require guarding in the same way as other moving machinery.

Where the fan is accessible to untrained personnel or the general public, use maximum safety guards, even at the cost of some performance loss. Unprotected fans located less than 7' above the floor also require guarding as specified in the Occupational Safety and Health Act (OSHA). PennBarry strongly recommends the use of guards on all exposed nonducted fans, ceiling and wall mounted.

Centrifugal fans may be connected directly to ductwork which will prevent contact with the internal moving parts, but when the inlet or outlet is exposed, install a suitable guard.

**Replacement Parts**

Replace parts with components which duplicate original parts correctly. Incorrectly sized shafts, belts, pulleys, etc. can damage the fan.

Spare or replacement parts and prices are available upon request. Please supply the following information: Factory Order Number, Customer's Name and Order Number and Date. If this information is not available, furnish a complete description of the part required. Names of parts are shown on page 7. To order motors provide the HP, RPM, voltage, phase, hertz and type of enclosure.

### Typical Concrete Slab Roof Installation

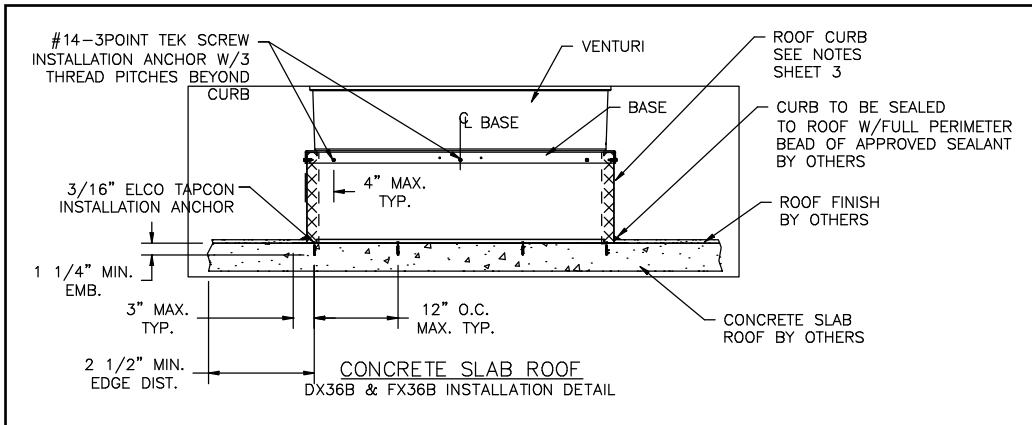

### Typical Steel Framed Roof Installation

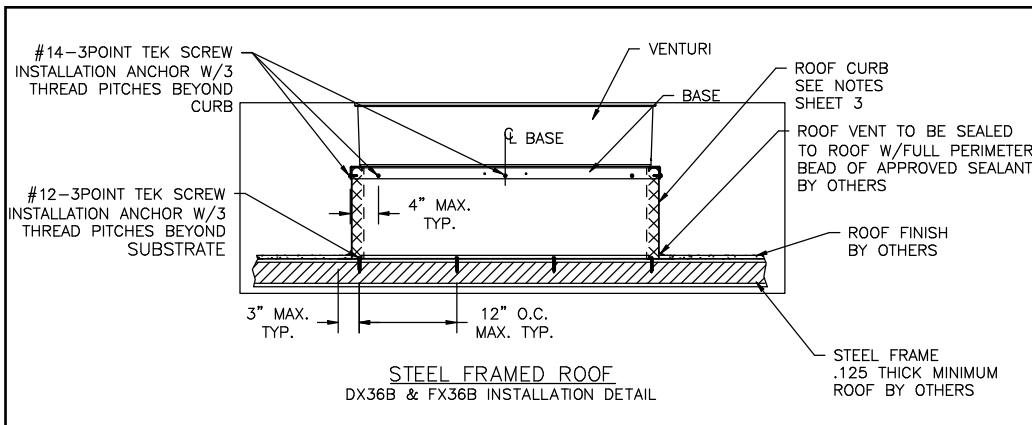

### Typical Wood Framed Roof Installation

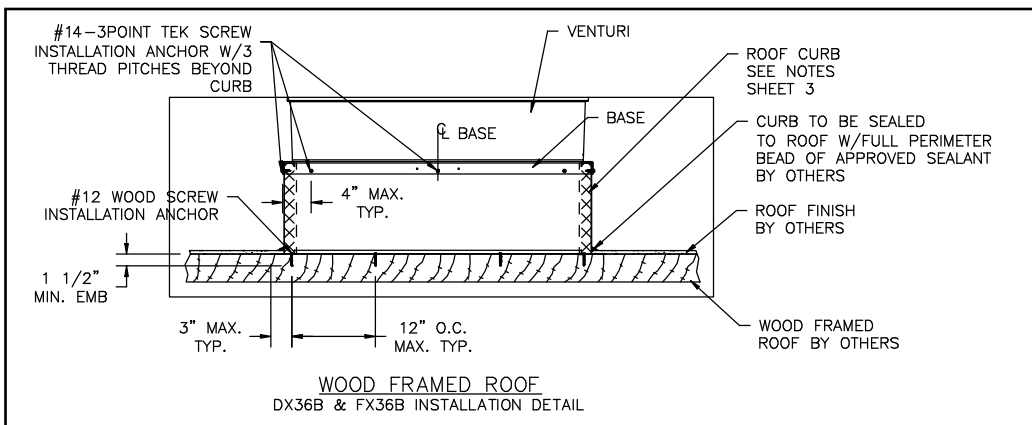

Installation Notes: All four sides of curb and base are anchored identically.

Curb Notes: 18 gauge galvanized steel minimum, maximum height 18"

# Wheel Alignment Procedures

**Figure 5: Wheel Alignment**

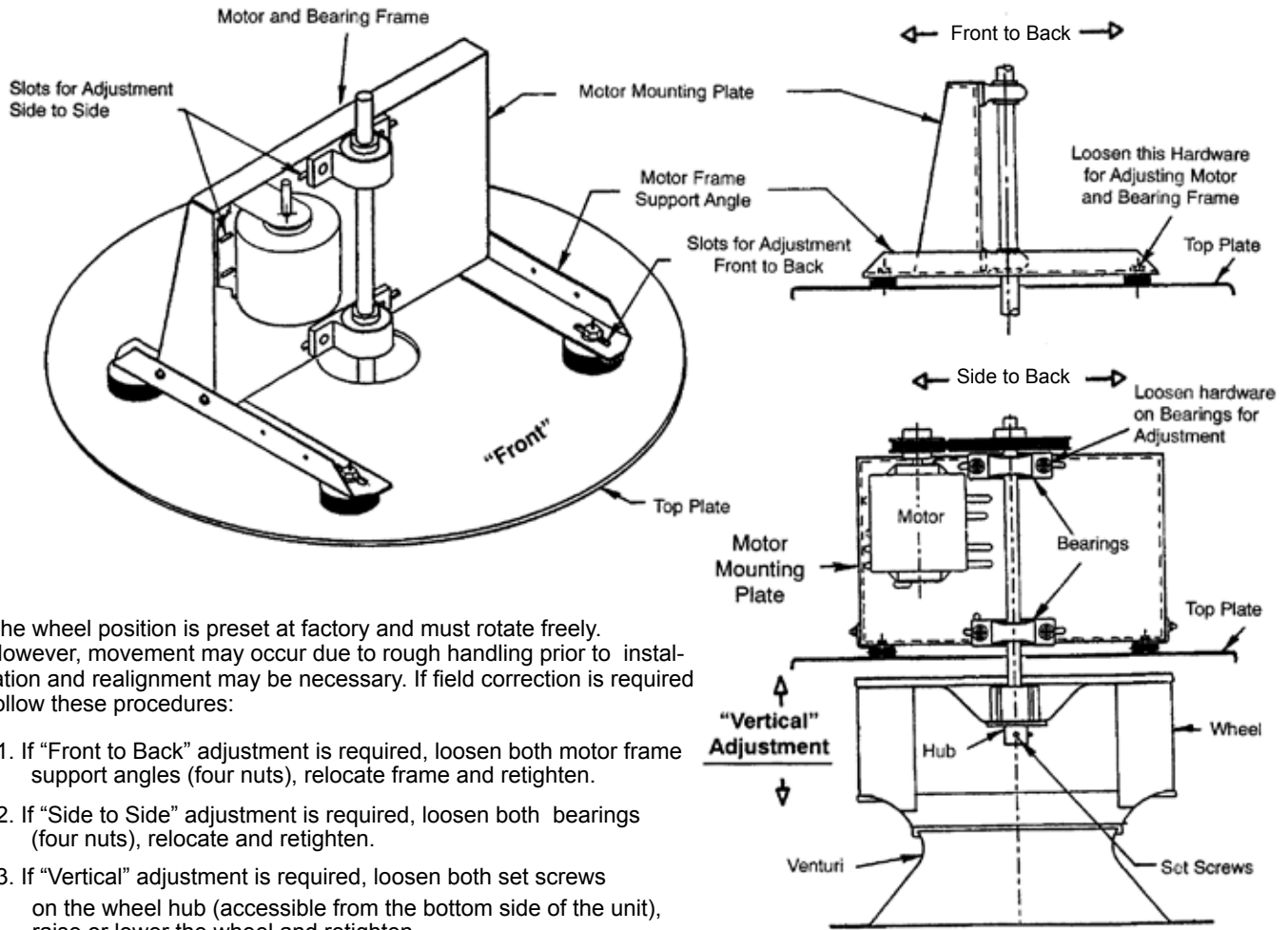

The wheel position is preset at factory and must rotate freely. However, movement may occur due to rough handling prior to installation and realignment may be necessary. If field correction is required follow these procedures:

1. If "Front to Back" adjustment is required, loosen both motor frame support angles (four nuts), relocate frame and retighten.
2. If "Side to Side" adjustment is required, loosen both bearings (four nuts), relocate and retighten.
3. If "Vertical" adjustment is required, loosen both set screws on the wheel hub (accessible from the bottom side of the unit), raise or lower the wheel and retighten.

# Troubleshooting Checklist

Symptom	Possible Cause(s)	Corrective Action
Excessive noise	<ol style="list-style-type: none"> <li>1. Defective or loose motor bearings</li> <li>2. Ventilator base not securely anchored</li> <li>3. Loose or unbalanced wheel/propeller</li> <li>4. Misaligned pulleys or shaft</li> <li>5. Loose or damaged wheel/propeller</li> <li>6. Wheel running in wrong direction</li> </ol>	<ol style="list-style-type: none"> <li>1. Replace motor with same frame size, RPM, HP</li> <li>2. Reset properly</li> <li>3. Tighten screws, remove build-up, balance wheel/propeller</li> <li>4. correct alignment</li> <li>4. Replace wheel/propeller</li> <li>6. Reverse direction</li> </ol>
Fan inoperative	<ol style="list-style-type: none"> <li>1. Blown fuse or open circuit breaker</li> <li>2. Loose or disconnected wiring</li> <li>3. Defective motor</li> <li>4. Broken belts</li> </ol>	<ol style="list-style-type: none"> <li>1. Replace fuses or circuit breaker</li> <li>2. Shut off power and check wiring for proper connections</li> <li>3. Repair or replace motor</li> <li>4. Replace belts</li> </ol>
Insufficient airflow	<ol style="list-style-type: none"> <li>1. Open access doors or loose sections of ducts</li> <li>2. Clogged filters</li> <li>3. Operation in wrong direction</li> <li>4. Insufficient make-up air direction</li> <li>5. Fan speed to low</li> </ol>	<ol style="list-style-type: none"> <li>1. Check for leakage</li> <li>2. Clean or replace filters</li> <li>3. Correct rotation of wheel</li> <li>4. Add make-up fan or louver opening</li> <li>5. Speed fan up by adjusting variable pitch pulley on motor shaft</li> </ol>
Water leaking into ductwork or collection of grease under fan	<ol style="list-style-type: none"> <li>1. Fan installed with slope in the wrong direction</li> <li>2. Clogged drain spout</li> <li>3. Cooling tube or motor dome top removed</li> <li>4. Grease container full</li> </ol>	<ol style="list-style-type: none"> <li>1. Slope should be fitted in the direction of the drainage opening or grease collection box and drain spout</li> <li>2. Clean drain spout</li> <li>3. Install new cooling tube with gasket and dome top</li> <li>4. Empty grease box</li> </ol>
Motor overheating	<ol style="list-style-type: none"> <li>1. Belt slippage</li> <li>2. Overvoltage or under voltage</li> <li>3. Operation in wrong direction</li> <li>4. Slow down fan by opening variable pitch</li> <li>5. Incorrect motor (service factor 1.0, low ambient temperature)</li> <li>6. Blocked cooling tube or leaky gasket</li> <li>7. Insufficient airflow to kitchen hood fan operating on low speed with kitchen in full operation.</li> <li>8. Undersized motor</li> </ol>	<ol style="list-style-type: none"> <li>1. Adjust tension or replace bad belts</li> <li>2. Contact power supply company</li> <li>3. Reverse direction of motor</li> <li>4. Fan speed too high pulley on motor shaft</li> <li>5. Replace motor with correct one, NEMA service factors (1.15 or higher) with 40 degrees ambient</li> <li>6. Remove blockage and seal cooling tube in place</li> <li>7. Check airflow under hood and adjust kitchen equipment output</li> <li>8. Check motor ratings with catalog speed and air capacity chart</li> </ol>

**Note:** Care should be taken to follow all local electrical, safety and building codes. Provisions of the National Electric Code (NEC), as well as the Occupational Safety and Health Act (OSHA) should be followed.

All motors are checked prior to shipment. If motor defects should develop, prompt service can be obtained from the nearest authorized service station of the motor manufacturer while under warranty. Exchange, repair or replacement will be provided on a no charge basis if the motor is defective within the warranty period. The PennBarry representative in your area will provide a name and address of an authorized service station if requested. **WARNING:** Motor guarantee is void unless overload protection is provided in motor wiring circuit.

# Parts Lists & Dimensions

## Direct Drive

**Figure 6: FX08RS, 10RS, 11RS, 11Q**

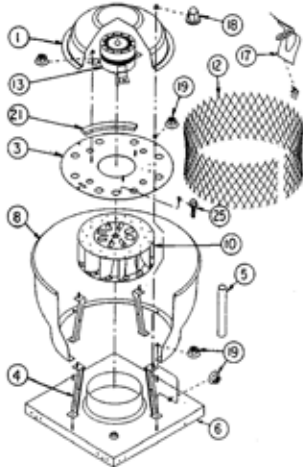

**Figure 7: FX13RSV, 13Q**

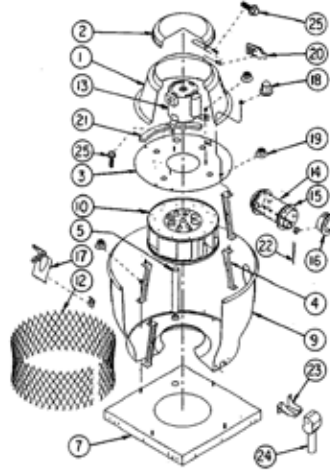

**Figure 8: FX16RSV, Q1, Q2**

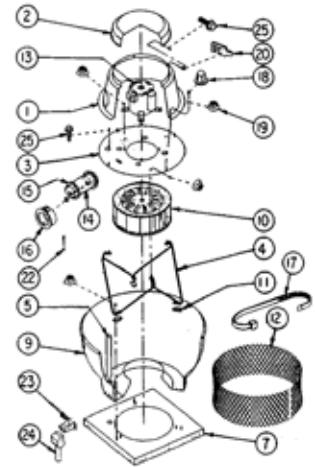

### Direct Drive Parts List

1. Hood Apron	6. Base Venturi	11. Wire Clip	16. Bushing	21. Gasket
2. Hood Top	7. Base (Round for WFX)	12. Screen (Optional)	17. Screen Clip	22. Cotter Pin
3. Top Plate	8. Discharge Apron	13. Motor	18. Acorn Nut	23. Drain Spout
4. Brace	9. Apron Venturi	14. Cooling Tube	19. 1/4 - 20 Nut	24. Down Spout
5. Conduit Pipe	10. Wheel	15. Clg. Tube Gasket	20. Clip	

Part	Description
1	Wind Band (2 pcs. FMX50B)
2	Discharge Apron
3	Cooling Tube
4	Cooling Tube Gaskets
5	Motor Hood Lid
6	Motor Hood
7	Motor & Bearing Frame
8	Anti-Vibration Mounts
9	Top Plate
10	Bird Guard (Optional)
11	Support Wires
12	Support Wire Mounting Clips
13	Conduit Guide
14	Venturi
15	Base (Round for WFX)
16	Fan Pulley
17	Belt
18	Motor Pulley
19	Motor
20	Bearings
21	Shaft
22	Centrifugal Wheel
23	Main Fastening Braces

**Figure 9: FX08B-FX36B**

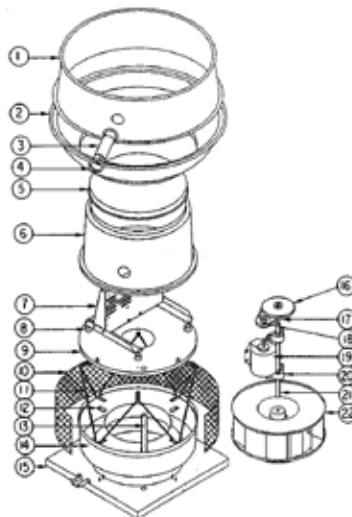

**Figure 10: FMX50B**

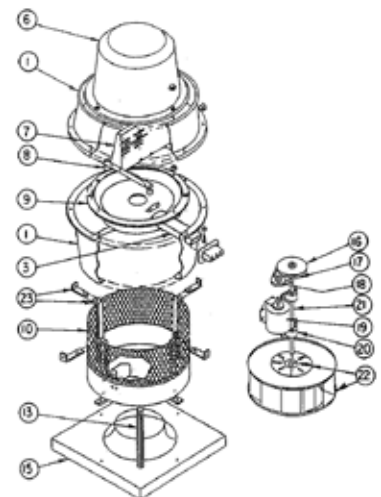

Fan Size	Direct Drive Models					Belt Drive Models										
	8	10	11	13	16	08B	10B	12B	13B(H)	14B	16B	18B(H)	24B(H)	30B	36B	50B
Base Dimensions	18.5	18.5	18.5	18.5	20.5	24.75	24.75	24.75	24.75	24.75	28.50	28.50	33.50	36.50	44.50	59.00

All dimensions are in inches. "E" - (outside curb dimension should be 1" smaller than inside fan base dimension)



# Direct Drive - Explosion Proof Motor

## Spun Aluminum Centrifugal Roof Exhauster

PUNCH OR DRILL HOLE FOR CONDUIT PATH. HOLE MUST BE SEALED OR CAULKED TO PREVENT WATER ENTRY.

RIGID CONDUIT OR I.M.C. (INTERMEDIATE METAL CONDUIT) PER N.E.C. AND/OR LOCAL CODES. (BY OTHERS)

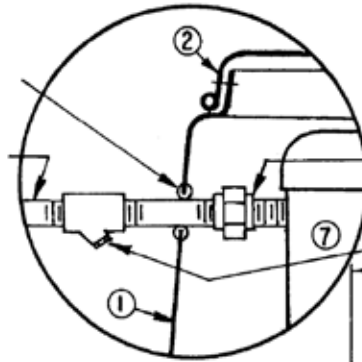

CLOSE NIPPLE AND UNION DIRECTLY OUT OF MOTOR.

N.E.C. SPECIFIES A SEAL WITHIN 18".

**\*NOTE-** ALL WIRING MUST BE PROVIDED BY A LICENSED ELECTRICIAN FAMILIAR WITH EXPLOSION PROOF WIRING PRACTICES AND REGULATIONS, USING COMPONENTS APPROPRIATE TO THE SPECIFIC INSTALLATION AND N.E.C. AND/OR LOCAL CODES.

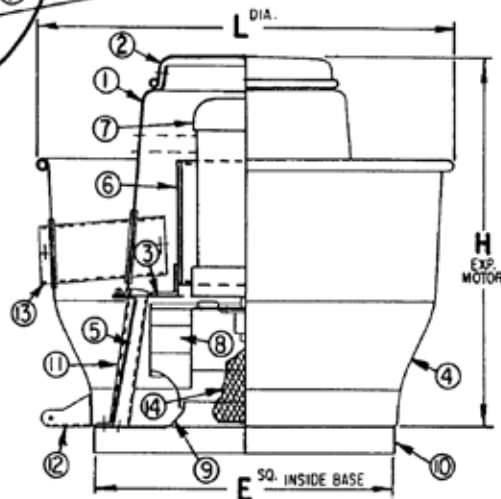

### Legend

- |                                    |   |   |
|------------------------------------|---|---|
| 1. Motor Dome                      | 7. Motor (Exp. Motor)                       | 12. Drain Spout (Models FX13 and FX16)  |
| 2. Motor Hood Top (For Exp. Motor) | 8. Centrifugal Fan Wheel with Cooling Vanes | 13. Cooling Tube (Models FX13 and FX16) |
| 3. Top Plate                       | 9. Spun Venturi                             | 14. Aluminum Bird Screen (Optional)     |
| 4. Discharge Apron                 | 10. Mounting Base                           |   |
| 5. Structural Support Braces       | 11. Conduit Guide (Not for Exp. Motor)      |   |
| 6. Motor Mounting Plate            |   |   |

### Dimensional Data

	FX08Q	FX10Q	FX11Q	FX13Q	FX16Q
L <sup>DIA.</sup>	25	25	25	25 1/2	30 1/2
H <sup>EXP. MOTOR</sup>	18	19	19	19	26 7/16
E <sup>†SQ.</sup>	18 1/2	18 1/2	18 1/2	18 1/2	20 1/2
Ro <sup>SQ.</sup>	9	11 1/2	11 1/2	11 1/2	16 1/4

† Outside dimension of curb should be 1 1/2" less than 'E' dimension

All dimensions in inches.

### Material: Spun Aluminum Housing

This drawing illustrates our understanding of order requirements. When approved, it represents details for fabrication, as such, PennBarry will not be responsible for revisions in the field or other changes after release for fabrication. Published and protected by PennBarry, Richardson, TX. All rights reserved. May not be reproduced partially or in full without permission from the publisher. No rights conveyed to manufacture partially or in full, use or sell either the method of construction represented or any invention in any way related thereto.

# Wiring Harness - Disconnect Device

## O.D.P. Motors (ITW Harness) 115/220 Single Phase

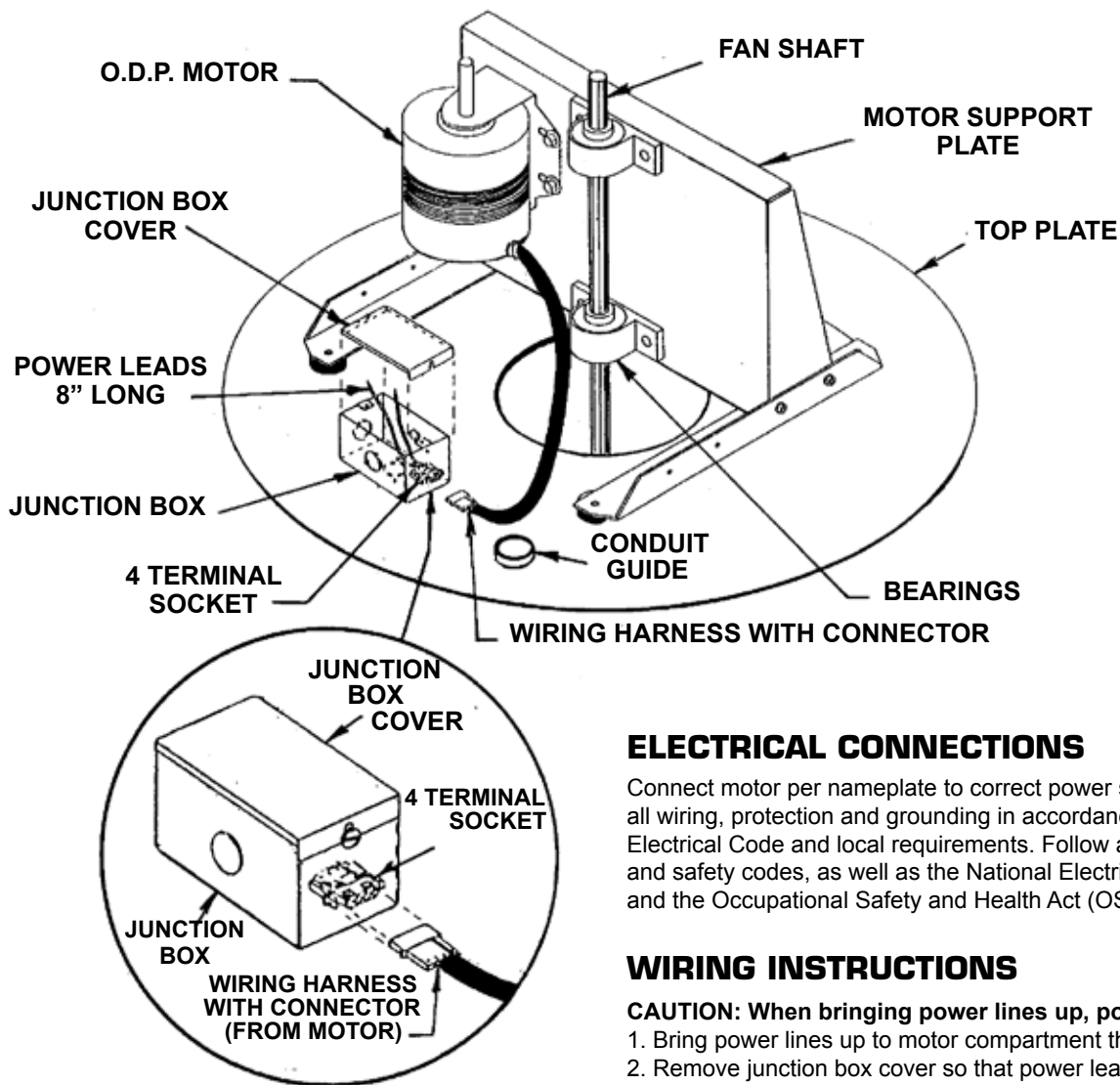

### ELECTRICAL CONNECTIONS

Connect motor per nameplate to correct power supply. Install all wiring, protection and grounding in accordance with National Electrical Code and local requirements. Follow all local electrical and safety codes, as well as the National Electrical Code (NEC) and the Occupational Safety and Health Act (OSHA).

### WIRING INSTRUCTIONS

**CAUTION: When bringing power lines up, power MUST be off.**

1. Bring power lines up to motor compartment thru conduit guide.
2. Remove junction box cover so that power leads are exposed.
3. Remove one knock-out, attach connector and run power lines from source into junction box.
4. Terminal socket has two 8" long pigtails already stripped. Make connection to power lines using proper size wire nuts and fold wires back into box.
5. Replace junction box cover and secure in place with screw.
6. Plug harness connector (from motor) into terminal socket at end of junction box. Unit is now ready to test.

This drawing illustrates our understanding of order requirements. When approved, it represents details for fabrication, as such, PennBarry will not be responsible for revisions in the field or other changes after release for fabrication. Published and protected by PennBarry, Richardson, TX. All rights reserved. May not be reproduced partially or in full without permission from the publisher. No rights conveyed to manufacture partially or in full, use or sell either the method of construction represented or any invention in any way related thereto.

---

# Limited One Year Warranty

---

## What Products Are Covered

PennBarry Fans and Ventilators (each, a “PennBarry Product”)

## One Year Limited Warranty For PennBarry Products

PennBarry warrants to the original commercial purchaser that the PennBarry Products will be free from defects in material and workmanship for a period of one (1) year from the date of shipment.

## Exclusive Remedy

PennBarry will, at its option, repair or replace (without removal or installation) the affected components of any defective PennBarry Product; repair or replace (without removal or installation) the entire defective PennBarry Product; or refund the invoice price of the PennBarry Product. In all cases, a reasonable time period must be allowed for warranty repairs to be completed.

## What You Must Do

In order to make a claim under these warranties:

1. You must be the original commercial purchaser of the PennBarry Product.
2. You must promptly notify us, within the warranty period, of any defect and provide us with any substantiation that we may reasonably request.
3. The PennBarry Product must have been installed and maintained in accordance with good industry practice and any specific PennBarry recommendations.

## Exclusions

These warranties do not cover defects caused by:

1. Improper design or operation of the system into which the PennBarry Product is incorporated.
2. Improper installation.
3. Accident, abuse or misuse.
4. Unreasonable use (including any use for non-commercial purposes, failure to provide reasonable and necessary maintenance as specified by PennBarry, misapplication and operation in excess of stated performance characteristics).
5. Components not manufactured by PennBarry.

## Limitations

1. In all cases, PennBarry reserves the right to fully satisfy its obligations under the Limited Warranties by refunding the invoice price of the defective PennBarry Product (or, if the PennBarry Product has been discontinued, of the most nearly comparable current product).
2. PennBarry reserves the right to furnish a substitute or replacement component or product in the event a PennBarry Product or any component of the product is discontinued or otherwise unavailable.
3. PennBarry's only obligation with respect to components not manufactured by PennBarry shall be to pass through the warranty made by the manufacturer of the defective component.

## General

**The foregoing warranties are exclusive and in lieu of all other warranties except that of title, whether written, oral or implied, in fact or in law (including any warranty of merchantability or fitness for a particular purpose).**

**PennBarry hereby disclaims any liability for special, punitive, indirect, incidental or consequential damages, including without limitation lost profits or revenues, loss of use of equipment, cost of capital, cost of substitute products, facilities or services, downtime, shutdown or slowdown costs.**

The remedies of the original commercial purchaser set forth herein are exclusive and the liability of PennBarry with respect to the PennBarry Products, whether in contract, tort, warranty, strict liability or other legal theory shall not exceed the invoice price charged by PennBarry to its customer for the affected PennBarry Product at the time the claim is made.

Inquiries regarding these warranties should be sent to: PennBarry, 1401 North Plano Road, Richardson, TX 75081.