



## Commercial Compact Hood CRS Series

★★★★★  
AT YOUR SERVICE  
SINCE  
1986

**CADEXAIR**  
EXPERTISE & INNOVATION

# CRS Series Commercial Compact Hood

## Built-in exhaust fan and fire protection system



This commercial compact hood is designed to meet the needs of small restaurants, company cafeterias, daycare centres, seniors' homes or institutional kitchens. Made for easy maintenance, the CRS hood series features a revolutionary degreasing system combined with an integrated radial turbine fan. This patented technique offers a complete and highly efficient package. The aerodynamic position of the centrifugal grease extractor allows optimal capture of steam, smoke and odours generated by cooking appliances. The integrated fire protection system combines economy of space and aesthetic appeal.



### Construction and options

- ULC-certified hood constructed entirely of 18MSG stainless steel. The installation of this range hood must meet the standards for ventilating commercial kitchens (NFPA96).
- Integrated halogen lighting (2 x 50 W).
- High-efficiency centrifugal extractor.
- The CRS-36 and CRS-48 models have an integrated automatic fire protection system. An on-site fire protection start-up by a certified ANSUL RIO2 technician is required.
- Inline 120V fan.
- Optional ceramic fire wool insulation for side and rear panels if 18" distance from combustible material is not possible.
- Control panel options:
  - CC25V: Exhaust speed control with dimmer.
  - CC25: Dry contact for exhaust and air supply.
  - CC35 series: PLC with custom design.

### Control sequence

The ventilation and lighting are operated using the Cadexair control panel. If there is a fire under the hood or the manual pull station is activated:

- The cooking surface, inside of the hood and fan will be sprayed with the liquid solution from the fire protection system.
- The exhaust fan must remain in operation.
- The lighting in the hood will be interrupted.
- The supply of gas or electricity to the cooking appliances will be interrupted.
- The "FIRE" and "COOKING OFF" lights will turn on.
- A signal from the fire protection system will be sent to the building's alarm system.
- The air supply will be turned off (CC25 or CC35 series control panel).

## Typical drawing for CRS series hood

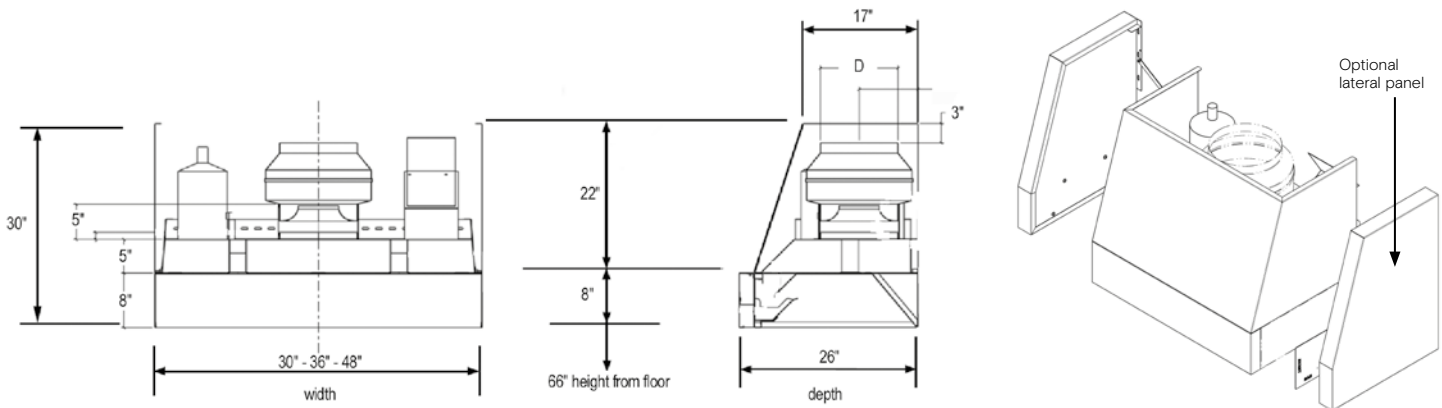

## Typical connection for CC25 and CC25V

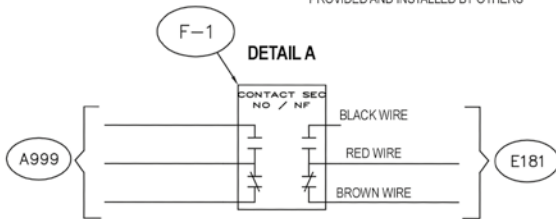
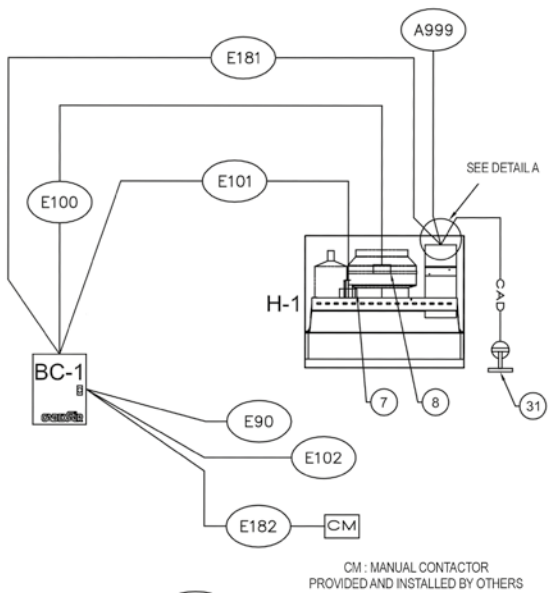

CC25

CC25V



## Electricity and control

#	Conductor #, Type	Function
A999	2C, dry contact	Building alarm monitoring to hood fire protection system
E90	2C, 120V, 20 amp	Box wiring for control, lighting and evacuator
E100	2C, 120V, 10 amp max.	Wiring for hood lighting junction boxes
E101	2C, 120V	Wiring for evacuator starter 120V coil
E102	2C, dry contact	Dry contact for air supply starter
E181	2C, 120V	Fire protection system monitoring status, NC contact
E182	2C, dry contact, 3 amp max.	Wiring for cooking equipment cutoff via magnetic contactor

## Alarm

#	Conductor #, Type	Function
109	2C, alarm	Wiring to building alarm

#	Item
H-1	Cadexair CRS series hood
BC-1	CC25 or CC25V control panel
7	Junction box
8	Motor junction box
31	Manual switch

## Data sheet

Model	Hood length (in)	Dim (D) flange (in)	Air flow in CFM by static pressure				120V motor (watts)	120V lighting (watts)	Fire protection gallonage	Weight (lbs)
			1/8"	3/8"	5/8"	7/8"				
CRS-30-M	30	8	494	412	353	271	160	2 x 50	N/A*	90
CRS-36-MA	36	12	677	553	459	365	190	2 x 50	1.5	130
CRS-36-MB	36	12	945	796	615	453	345	2 x 50	1.5	130
CRS-48-M	48	12	945	796	615	453	345	2 x 50	1.5**	150

\* The CRS-30-M hood cannot be installed with an integrated fire protection system. The installation must be completed on site.

\*\* Based on the cooking activity under the hood, it is possible to double the gallonage capacity if necessary.

## Information and options

The CRS36 hood can be equipped with a 190W or 345W fan. Cadexair recommends the 345W model for gas installations. An electrical gas cutoff valve will be needed for gas cooking equipment. If the hood is not linked to a Cadexair box, a rearming relay is mandatory.

Optional feature: Side panels insulated with ceramic wool for an 18" clearance from combustible material (e.g., wood cabinets). Add 6" to the length of the hood. Optional feature: Back panel insulated with ceramic wool. Add 3" to the width of the hood (e.g., wood wall).

An electrical shutoff valve will be needed for gas cooking equipment. If the hood is not connected to a Cadexair control panel, an autoreset relay must be installed.

Note: According to the Construction Code, the equipment must be entirely clear of combustible and semi-combustible material.



### Accessories

Mounting tabs	✓
Stainless steel #304 construction	✓
Junction box and pre-wiring for lighting	✓
Integrated centrifugal grease extractor	✓
Stainless steel enclosure panels between the hood and the ceiling	★
Approved two-position balancing damper	★
Built-in back spacer and/or side spacer	★
Ceramic wool fire insulation	★
CC35 series programmed control panel	★
Fire suppression system	★

Legend: ✓ included accessory  
★ available as an option

### Head office

1010 Lionel-Boulet Boulevard  
Varenes, QC, Canada J3X 1P7

### Quebec office

7625 Wilfred-Hamel Boulevard  
Quebec, QC, Canada G2G 1C3

### Contact us

Design, pricing and sales  
[sales@cadexair.com](mailto:sales@cadexair.com)

Technical support and cleaning  
[info@cadexair.com](mailto:info@cadexair.com)

450-652-0668  
1-800-461-0668

[cadexair.com](http://cadexair.com)

**CADEXAIR**  
EXPERTISE & INNOVATION